

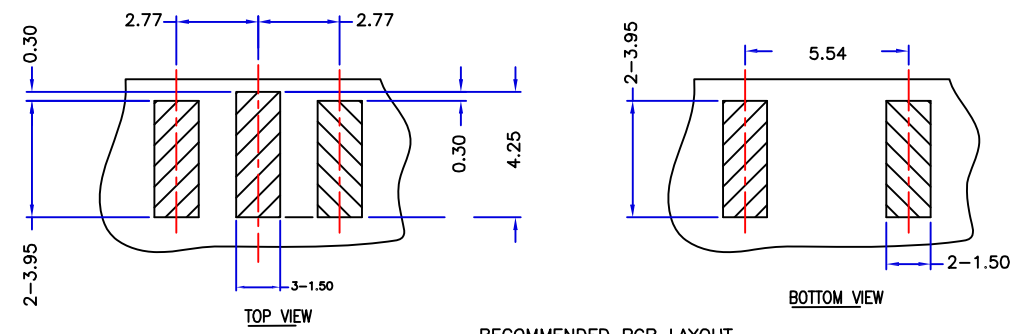

Product NO.		RHT-618-0099			
REV	DESCRIPTION	DWN	DATE	APPROVEN	
A	First issue	SAM	2017/03/14	JIM. KING	

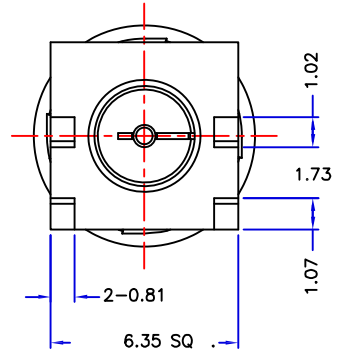
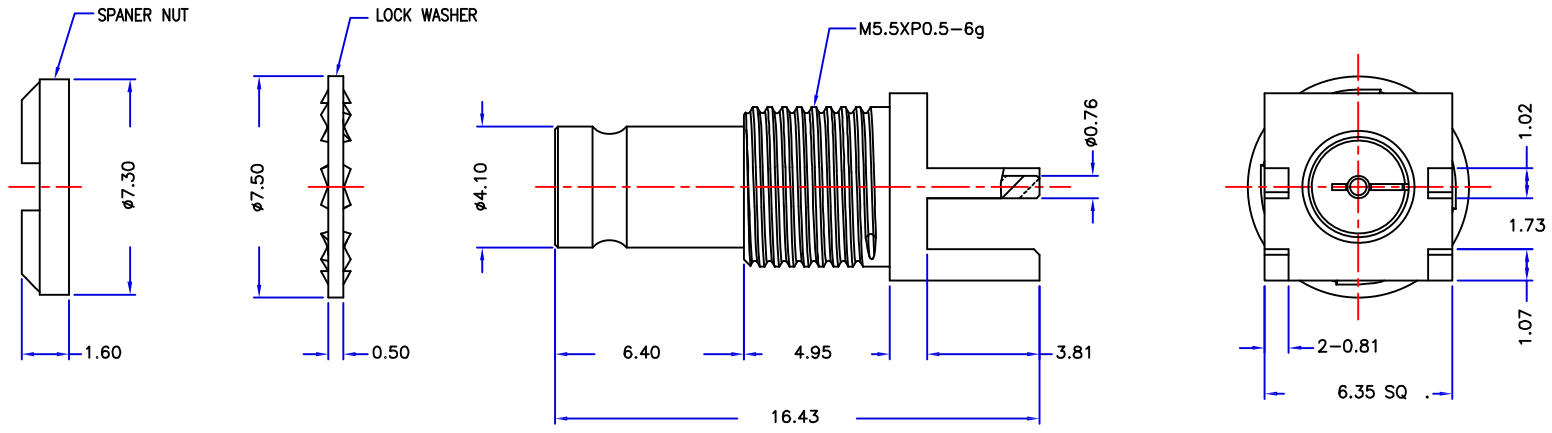

5	SPANNER NUT	BRASS	GOLD	1
4	LOCK WASHER	BRASS	GOLD	1
3	CONTACT PIN	BER. COPPER	GOLD	1
2	INSULATOR	PTFE	NATURAL	1
1	BODY	BRASS	GOLD	1
	DESCRIPTION	MATERIAL	FINISH	QTY

-TOLERANCES- UNLESS OTHERWISE SPECIFIED		<b>RENHOTEC GROUP</b> <a href="http://www.renhotec.com">www.renhotec.com</a>	
		Title: 1.0-2.3 JACK FOR PCB CONNECTOR-750HM	
		P/N: RHT-618-0099	
0. $\pm 0.15$	0.° $\pm 30^\circ$	Appd:	Date
0.0 $\pm 0.10$	0.0° $\pm 25^\circ$	Check: Xiong Tan	Scale
0.00 $\pm 0.05$	0.00° $\pm 20^\circ$	Draw: Owen	Unit
		2017.03.14	Type
		Free	Page
		MM	1/1
		Z	