

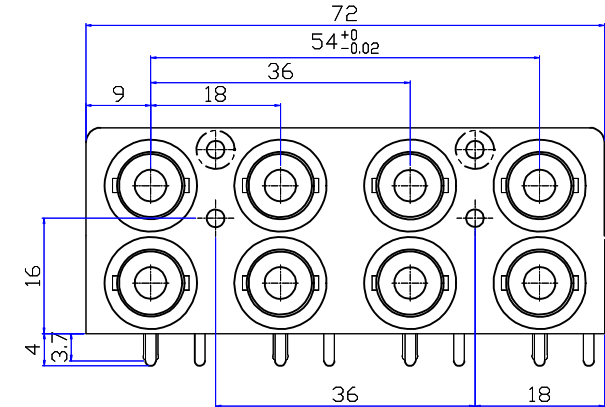

Product NO.	Renhotec-610-0015			
REV	DESCRIPTION	DWN	DATE	APPROVEN
A	First issue	Mr. Wang	2016/3/02	John kine

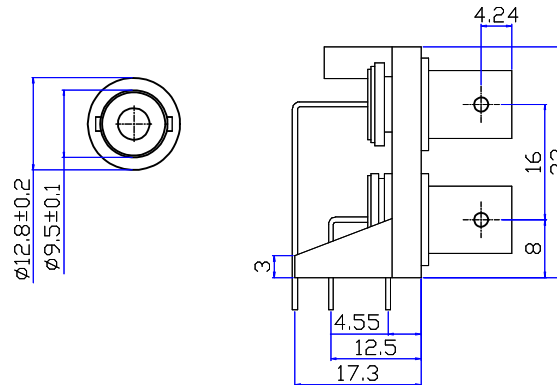
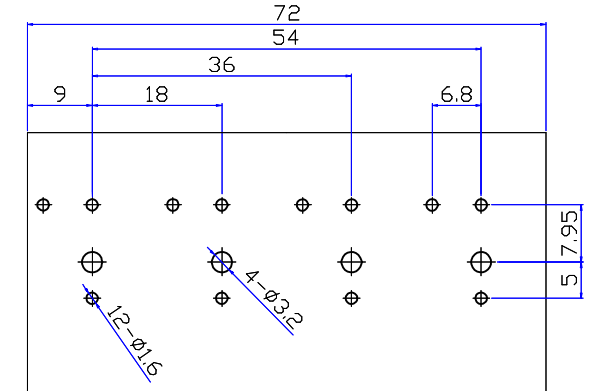
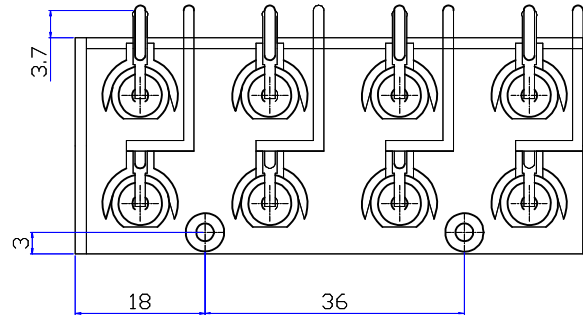
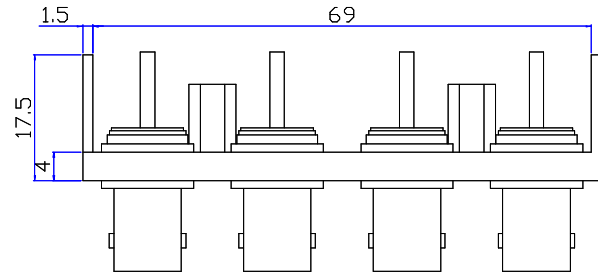

### Specifications

Impedance: 50 Ohms  
 Frequency Range: DC~3G  
 VSWR: 1.3MAX  
 Working Voltage: 500V rms @ sea level  
 Insulation Resistance: 5000 Ohms min  
 Temperature Range: -55°C TO +155°C  
 Relative Humidity: ≤95% (40°C ±2°C)  
 Drawings products are in line with ROHS standards

NOTE:

Tolerance

0-6 ±0.10  
 6-30 ±0.20  
 30-120 ±0.30  
 Angular ±2°

View

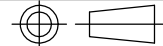

UNIT

MM

SCALE

1:1



**RENHOTEC GROUP**

Name: BNC 2x4 CONNECTOR DGN

SIZE	Product NO. RENHOTEC-610-0015	REV
A		B

DateTime	CAD FILE	SHEET: 1 OF 1
2016/3/02	D/company drawings/BD	

NO	DESCRIPTION	MATERIAL	FINISH	QTY
6	Insulator	POM	-----	8
5	Solder column	Iron	NICKEL	8
4	IRON PLATES	Iron	NICKEL	1
3	PANEL	ABS	BLACK	1
2	PIN	BRASS	NICKEL	8
1	BODY	ZINC	NICKEL	8

APPROVALS  
*John Kine* 09.03.2016